

Tackle Block and Sheave Assembly

Warning, Use & Maintenance Information

WARNING

- A potential hazard exists when lifting or dragging heavy loads with tackle block assemblies.
- Failure to design and use tackle block systems properly may cause a load to slip or fall – the result could be serious injury or death.
- Failure to design lifting system with appropriate sheave assembly material for the intended application may cause premature sheave, bearing or wire rope wear and ultimate failure – the result could be serious injury or death.
- A tackle block system should be rigged by a qualified person as defined by ANSI/ASME B.30.
- Instruct workers to keep hands and body away from block sheaves and swivels – and away from “pinch points” where rope touches block parts or loads.
- Do not side load tackle blocks.
- See OSHA Rule 1926.550(g) for personnel hoisting by cranes and derricks, and OSHA Directive CPL 2-1.29 — Interim Inspection Procedures During Communication Tower Construction Activities. Only a Crosby or McKissick Hook with a PL latch attached and secured with a bolt, nut and cotter pin (or toggle pin) or a PL-N latch attached and secured with toggle pin; or a Crosby hook with an S-4320 latch attached and secured with cotter pin or bolt, nut and pin; or a Crosby SHUR-LOC® Hook in the locked position may be used for any personnel hoisting. A hook with a Crosby SS-4055 latch attached shall NOT be used for personnel lifting.
- Instruct workers to be alert and to wear proper safety gear in areas where loads are moved or supported with tackle block systems.
- Use only genuine Crosby parts as replacement.
- Read, understand, and follow these instructions to select, use and maintain tackle block systems.

General Cautions or Warnings

Ratings shown in Crosby Group literature are applicable only to new or “in as new” products.

Working Load Limit ratings indicate the greatest force or load a product can carry under usual environmental conditions. Shock loading and extraordinary conditions must be taken into account when selecting products for use in tackle block systems. Working Load Limit ratings are based on all sheaves of tackle block system being utilized. If all sheaves are not utilized, balance must be maintained, and the working Load Limit must be reduced proportionally to prevent overloading sheave components. Changes from full sheave reeving arrangement should be only at the recommendation of a qualified person, and incorporate good rigging practices.

In general, the products displayed in Crosby Group literature are used as parts of a system being employed to accomplish a task. Therefore, we can only recommend within the working Load Limits, or other stated limitations, the use of products for this purpose.

The Working Load Limit or Design (Safety) Factor of each Crosby product may be affected by wear, misuse, overloading, corrosion, deformation, intentional alteration, and other use conditions. Regular inspection must be conducted to determine whether use can be continued at the catalog assigned WLL, a reduced WLL, a reduced Design (Safety) Factor, or withdrawn from service.

Crosby Group products generally are intended for tension or pull. Side loading must be avoided, as it exerts additional force or loading which the product is not designed to accommodate.

Always make sure the hook supports the load. The latch must never support the load.

Welding of load supporting parts or products can be hazardous. Knowledge of materials, heat treatment, and welding procedures are necessary for proper welding. Crosby Group should be consulted for information.

Definitions

STATIC LOAD – The load resulting from a constantly applied force or load.

WORKING LOAD LIMIT – The maximum mass or force which the product is authorized to support in general service when the pull is applied in-line, unless noted otherwise, with respect to the center line of the product. This term is used interchangeably with the following terms.

1. WLL
2. Rated Load Value
3. SWL
4. Safe Working Load
5. Resultant Safe Working Load

WORKING LOAD – The maximum mass or force which the product is authorized to support in a particular service.

PROOF LOAD – The average force applied in the performance of a proof test; the average force to which a product may be subjected before deformation occurs.

PROOF TEST – A test applied to a product solely to determine non conforming material or manufacturing defects.

ULTIMATE LOAD – The average load or force at which the product fails, or no longer supports the load.

SHOCK LOAD – A force that results from the rapid application of a force (such as impacting and/or jerking) or rapid movement of a static load. A shock load significantly adds to the static load.

DESIGN (SAFETY) FACTOR – An industry term denoting a product's theoretical reserve capability; usually computed by dividing the catalog Ultimate Load by the Working Load Limit. Generally expressed for blocks as a ratio of 4 to 1.

TACKLE BLOCK – An assembly consisting of a sheave(s), side plates, and generally an end fitting (hook, shackle, etc.) that is used for lifting, lowering, or applying tension.

SHEAVE / SHEAVE BEARING ASSEMBLY – Purchased by O.E.M. or end user to be used in their block or lifting system design.

Fitting Maintenance

Fittings, including hooks, overhaul balls, shackles, links, etc., may become worn and disfigured with use, corrosion, and abuse resulting in nicks, gouges, worn threads and bearings, sharp corners which may produce additional stress conditions and reduce system load capacity.

Grinding is the recommended procedure to restore smooth surfaces. The maximum allowance for reduction of a product's original dimension due to wear or repair before removal from service is:

1. Any single direction - No more than 10% of original dimension;
2. Two directions - No more than 5% of each dimension.

For detailed instructions on specific products, see the application and warning information for that product. Any greater reduction may necessitate a reduced Working Load Limit.

Any crack or deformation in a fitting is sufficient cause to withdraw the product from service.

Tackle Blocks must be regularly inspected, lubricated, and maintained for peak efficiency and extended usefulness. Their proper use and maintenance is equal in importance to other mechanical equipment. The frequency of inspection and lubrication is dependent upon frequency and periods of use, environmental conditions, and the user's good judgment.

Inspection: As a minimum, the following points should be considered:

1. Wear on pins or axles, rope grooves, side plates, bushing or bearings, and fittings. (See Fitting Maintenance.) Excessive wear may be a cause to replace parts or remove block from service.
2. Deformation in side plates, pins and axles, fitting attachment points, trunnions, etc. Deformation can be caused by abusive service and / or overload and may be a cause to remove block from service.
3. Misalignment or wobble in sheaves.
4. Security of nuts, bolts, and other locking methods, especially after reassembly following a tear down inspection. Original securing method should be used; e.g., staking, set screw, cotter pin, cap screw.
5. Pins retained by snap rings should be checked for missing or loose rings.
6. Sheave pin nuts should be checked for proper positioning. Pins for tapered roller bearings should be tightened to remove all end play during sheave rotation. Pins for bronze bushings and straight roller bearings should have a running clearance of .031 inch per sheave of end play and should be adjusted accordingly.
7. Hook or shackle to swivel case clearance is set at .031 to .062 at the factory. Increased clearance can result from component wear. Clearance exceeding .12 to .18 should necessitate disassembly and further inspection.
8. Deformation or corrosion of hook and nut threads.
9. Surface condition and deformation of hook (See Fitting Maintenance and ANSI B30.10.)
10. Welded side plates for weld corrosion or weld cracking.
11. Hook latch for deformation, proper fit and operation.

Lubrication: The frequency of lubrication depends upon frequency and period of product use as well as environmental conditions, which are contingent upon the user's good judgment. Assuming normal product use, the following schedule is suggested when using lithium-base grease of a medium consistency.

Sheave Bearings

Tapered Roller Bearings—Every 40 hours of continuous operation or every 30 days of intermittent operation.

Roller Bearings—Every 24 hours of continuous operation or every 14 days of intermittent operation.

Bronze Bushings—(Not Self Lubricated)—Every 8 hours of continuous operation or every 14 days of intermittent operation.

Hook Bearings

Anti Friction—Every 14 days for frequent swiveling; every 45 days for infrequent swiveling.

Bronze Thrust Bushing or No Bearing—Every 16 hours for frequent swiveling; every 21 days for infrequent swiveling.

Tackle Block Maintenance also depends upon proper block selection (see "Loads on Blocks"), proper reeving (see "The Reeving of Tackle Blocks"), consideration of shock loads, side loading, and other adverse conditions.

SHEAVE BEARING APPLICATION INFORMATION

BRONZE BUSHINGS—

Bronze Bushings are used primarily for sheave applications using slow line speed, moderate load, and moderate use. The performance capability of a bearing is related to the bearing pressure and the bearing surface velocity by a relationship known as true PV (Maximum Pressure - Velocity Factor). The material properties of the Bronze Bushings furnished as standard in Crosby catalog sheaves are:

(BP) Maximum Bearing Pressure :4500 PSI

(BV) Maximum Velocity at Bearing :1200 FPM

(PV) Maximum Pressure Velocity Factor :55000

(It should be noted that due to material property relations, the maximum BP times the maximum BV is NOT equal to the maximum PV.)

Formula for Calculating Bearing Pressure:

$$BP = \frac{\text{Line Pull} \times \text{Angle Factor}}{\text{Shaft Size} \times \text{Hub Width}}$$

Note: Angle factor Multipliers listed on page 19

Formula for Calculating Bearing Velocity:

$$BV = \frac{PV}{BP}$$

Formula for Calculating Line Speed:

$$\text{Line Speed} = \frac{BV (\text{Tread Diameter} + \text{Rope Diameter})}{\text{Shaft Diameter}}$$

TACKLE BLOCK MAINTENANCE

Calculations can be made to find the maximum allowable line speed for a given total sheave load. If the required line speed is greater than the maximum allowable line speed calculated, then increase the shaft size and/or the hub width and recalculate. Continue the process until the maximum allowable line speed is equal to or exceeds the required line speed.

Example

Using a 14 in. sheave (Stock # 917191; refer to wire rope sheave section of 950 General Catalog for dimensions) with a 4600 lb. line pull and an 80° angle between lines determine maximum allowable line speed.

$$BP = \frac{(4600 \text{ lb.} \times 1.53)}{(\text{line pull}) \quad (\text{angle factor})} \div \frac{(1.50 \times 1.62)}{(\text{Shaft Size}) \quad (\text{Hub Width})} = 2896 \text{ PSI}$$

$$BV = \frac{55000}{(\text{PV Factor})} \div \frac{2896}{(\text{BP})} = 19 \text{ FPM ALLOWABLE}$$

$$\text{Line Speed} = 19 \times \frac{(12 + .75)}{(\text{BV}) \quad (\text{Tread Dia} + \text{Rope Size})} \div \frac{1.50}{(\text{Shaft Dia.})} = 161.5 \text{ FPM ALLOWABLE}$$

If the application required a line speed equal to 200 FPM, then another calculation would be necessary. Trying another 14 in. sheave (stock # 4104828) under the same loading conditions, the results are as follows:

$$BP = (4600 \text{ lbs.} \times 1.53) \div (2.75 \times 2.31) = 1108 \text{ PSI}$$

$$BV = 55000 \div 1108 = 50 \text{ FPM}$$

$$\text{Line Speed} = 50 \times (12.25 + .75) \div 2.75 = 236 \text{ FPM ALLOWABLE}$$

COMMON (PLAIN) BORE—Very slow line speed, very infrequent use, low load.

ROLLER BEARING—Faster line speeds, more frequent use, greater load. Refer to manufacturer's rating.

LOADS ON BLOCKS

The Working Load Limit (WLL) for Crosby Group blocks indicates the maximum load that should be exerted on the block and its connecting fitting.

This total load value may be different from the weight being lifted or pulled by a hoisting or hauling system. It is necessary to determine the total load being imposed on each block in the system to properly determine the rated capacity block to be used.

A single sheave block used to change load line direction can be subjected to total loads greatly different from the weight being lifted or pulled. The total load value varies with the angle between the incoming and departing lines to the block.

The following chart indicates the factor to be multiplied by the line pull to obtain the total load on the block.

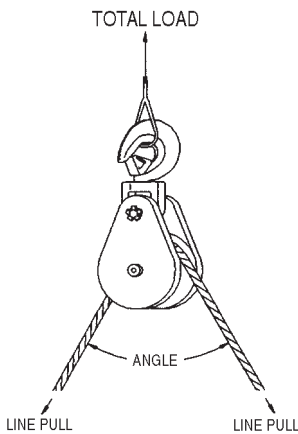

ANGLE FACTOR MULTIPLIERS			
ANGLE	FACTOR	ANGLE	FACTOR
0°	2.00	100°	1.29
10°	1.99	110°	1.15
20°	1.97	120°	1.00
30°	1.93	130°	.84
40°	1.87	135°	.76
45°	1.84	140°	.68
50°	1.81	150°	.52
60°	1.73	160°	.35
70°	1.64	170°	.17
80°	1.53	180°	.00
90°	1.41	—	—

Example A

(Calculations for determining total load value on single line system.)

A gin pole truck lifting 1,000 lbs.

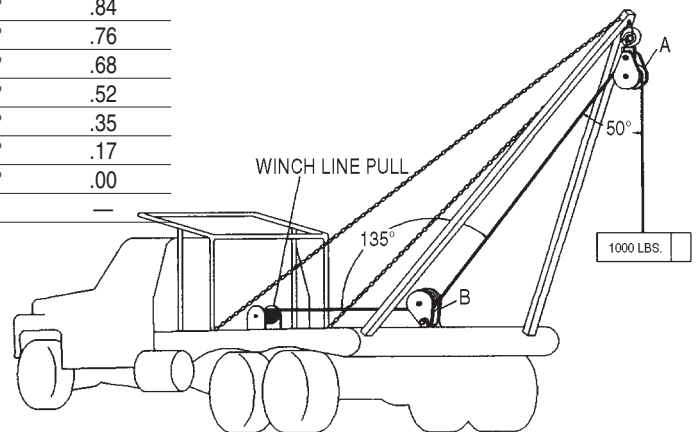

There is no mechanical advantage to a single part load line system, so winch line pull is equal to 1,000 lbs. or the weight being lifted.

To determine total load on snatch block A: $A = 1,000 \text{ lbs.} \times 1.81 = 1,810 \text{ lbs.}$
 (line pull) (factor 50° angle)

To determine total load on toggle block B: $B = 1,000 \text{ lbs.} \times .76 = 760 \text{ lbs.}$
 (line pull) (factor 135° angle)

Example B

(Calculation for determining total load value for mechanical advantage system.)

Hoisting system lifting 1,000 lbs. using a traveling block.

The mechanical advantage of traveling block C is 2.00 because two (2) parts of load line support the 1,000 lb. weight. (To determine single line pull for various bearing efficiency see "How to Figure Line Parts" page 109).

To Determine Line Pull:

$$\text{Line Pull} = 1000 \text{ lbs.} \div 2.00 = 500 \text{ lbs.}$$

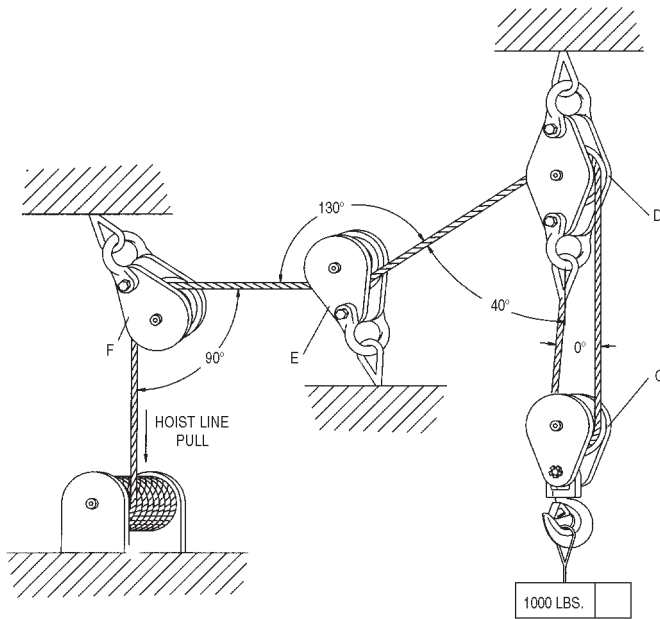

To determine total load on traveling block

$$C = 500 \text{ lbs. (line pull)} \times 2.0 \text{ (Factor } 0^\circ \text{ angle)} = 1,000 \text{ lbs.}$$

To determine total load on stationary block D:

$$D = 500 \text{ lbs. (line pull)} \times 1.87 \text{ (Factor } 40^\circ \text{ angle)} + 500 \text{ lbs. (dead end load)} = 1,435 \text{ lbs.}$$

To determine total load on block E:

$$E = 500 \text{ lbs. (line pull)} \times .84 \text{ (Factor } 130^\circ \text{ angle)} = 420 \text{ lbs.}$$

To determine total load on block F:

$$F = 500 \text{ lbs. (line pull)} \times 1.41 \text{ (Factor } 90^\circ \text{ angle)} = 705 \text{ lbs.}$$

THE REEVING OF TACKLE BLOCKS

In reeving of tackle blocks, there are many methods. The method discussed below is referred to as "Right Angle" reeving. Please consult your rigging manual for other methods of reeving.

RIGHT ANGLE REEVING

In reeving a pair of tackle blocks, one of which has more than two sheaves, the hoisting rope should lead from one of the center sheaves of the upper block to prevent toppling and avoid injury to the rope. The two blocks should be placed so that the sheaves in the upper block are at right angles to those in the lower one, as shown in the following illustrations.

Start reeving with the becket or dead end of the rope. Use a shackle block as the upper one of a pair and a hook block as the lower one as seen below.

Sheaves in a set of blocks revolve at different rates of speed. Those nearest the lead line revolve at the highest rate of speed and wear out more rapidly.

All sheaves should be kept well lubricated when in operation to reduce friction and wear.

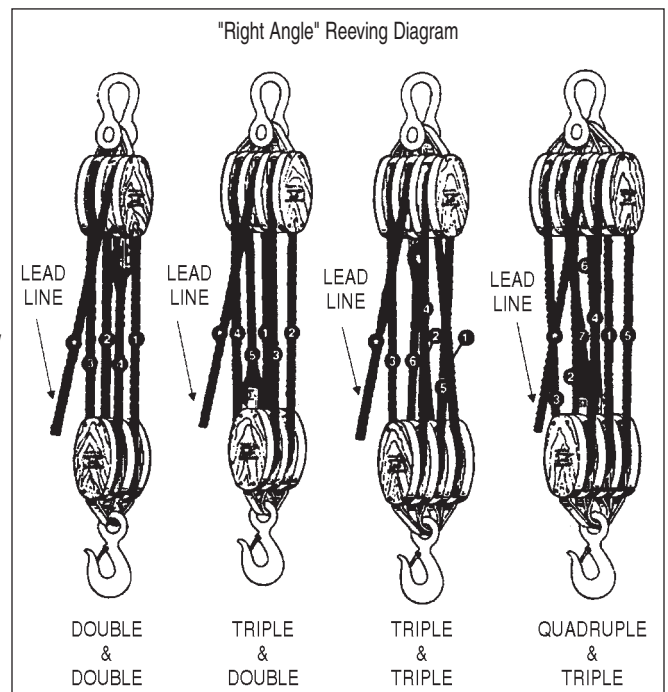

TACKLE BLOCK INFORMATION

SHEAVE SIZE AND WIRE ROPE STRENGTH

Strength Efficiency

Bending wire rope reduces its strength. To account for the effect of bend radius on wire rope strength when selecting a sheave, use the table below.

RATIO A	STRENGTH EFFICIENCY COMPARED TO CATALOG STRENGTH IN %
40	95
30	93
20	91
15	89
10	86
8	83
6	79
4	75
2	65
1	50

Fatigue Life

Repeated bending and straightening of wire rope causes a cyclic change of stress called "fatiguing." Bend radius affects wire rope fatigue life. A comparison of the relative effect of sheave diameter on wire rope fatigue life can be determined as shown below:

RATIO B	RELATIVE FATIGUE BENDING LIFE
30	10.0
25	6.6
20	3.8
18	2.9
16	2.1
14	1.5
12	1.1

STRESS FORMULA

$L \times A = S$ L = Load in lbs. A = Angle factor S = Stress in lbs.

SAMPLE: By using a 500 lb. weight, the stress exerted on the eye would be 1,000 lbs.

$$\begin{array}{cccccc} L & \times & A & = & S \\ 500 \text{ lbs.} & \times & 2.0 & = & 1,000 \text{ lbs.} \end{array}$$

See Chart 1 Below for Angle Factors

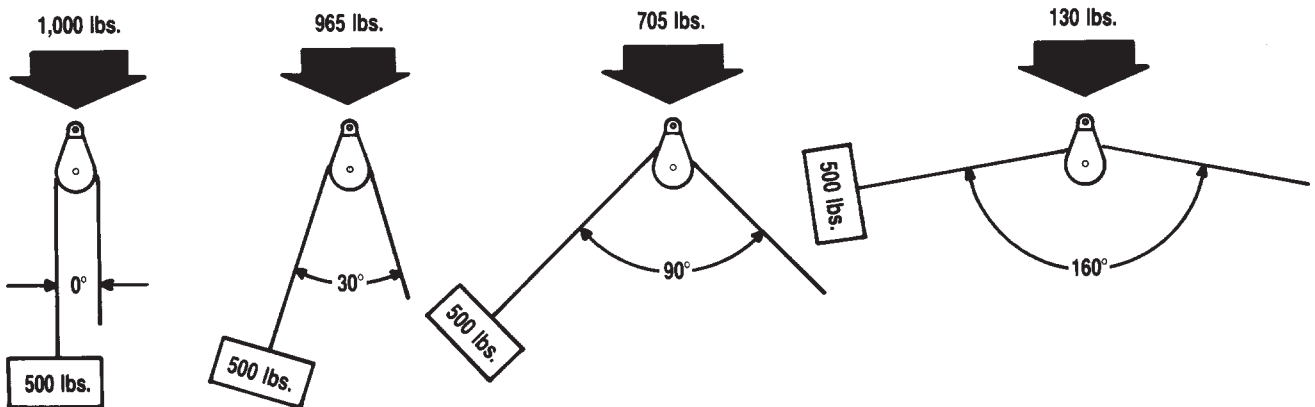

ANGLE	FACTOR	ANGLE	FACTOR	ANGLE	FACTOR
0°	2.0	70°	1.64	140°	.680
10°	1.98	80°	1.53	150°	.520
20°	1.97	90°	1.41	160°	.350
30°	1.93	100°	1.29	170°	.170
40°	1.87	110°	1.150	180°	.000
50°	1.81	120°	1.000		
60°	1.73	130°	.840		

HOW TO DETERMINE OVERHAULING WEIGHTS

To determine the weight of the block or overhaul ball that is required to free fall the block, the following information is needed: size of wire rope, number of line parts, type of sheave bearing, length of crane boom, and drum friction (use 50 pounds, unless other information is available).

The Formula is:

$$\text{Required Block Weight} = [(\text{Boom Length} \times \text{Factor A}) + \text{Drum Friction}] \times \text{Factor B}$$

Example

To determine the required block or overhaul weight using 5 parts of 7/8" diameter wire rope, a 50 ft. boom and roller bearing sheaves:

$$\text{Required Block Weight} = [(50 \text{ ft.} \times 1.42) + 50 \text{ lbs.}] \times 5.38 = 651 \text{ lbs.}$$

(Boom length) Factor A (Drum Friction) (Factor B)

WIRE ROPE SIZE (INCHES)	FACTOR A—WIRE ROPE WEIGHT LBS. PER FT., 6 X 19 IWRC
3/8	.26
7/16	.35
1/2	.46
9/16	.59
5/8	.72
3/4	1.04
7/8	1.42
1	1.85
1-1/8	2.34
1-1/4	2.89

NUMBER OF LINE PARTS	FACTOR B—OVERHAUL FACTORS	
	ROLLER BEARING SHEAVES	BRONZE BUSHED SHEAVES
1	1.03	1.05
2	2.07	2.14
3	3.15	3.28
4	4.25	4.48
5	5.38	5.72
6	6.54	7.03
7	7.73	8.39
8	8.94	9.80
9	10.20	11.30
10	11.50	12.80

HOW TO FIGURE LINE PARTS

To help figure the number of parts of line to be used for a given load, or the line pull required for a given load, (For example use reeving diagram on page 20. Only numbered lines shall be used in the calculation). The following ratio table is provided with examples of how to use it.

RATIO A BRONZE BUSHED SHEAVES	RATIO B ANTI-FRICTION BEARING SHEAVES	NUMBER OF LINE PARTS
.96	.98	1
1.87	1.94	2
2.75	2.88	3
3.59	3.81	4
4.39	4.71	5
5.16	5.60	6
5.90	6.47	7
6.60	7.32	8
7.27	8.16	9
7.91	8.98	10
8.52	9.79	11
9.11	10.60	12
9.68	11.40	13
10.20	12.10	14
10.70	12.90	15
11.20	13.60	16
11.70	14.30	17
12.20	15.00	18
12.60	15.70	19
13.00	16.40	20

$$\text{Ratio A or B} = \frac{\text{Total Load to be Lifted}}{\text{Single Line Pull (lbs.)}}$$

After calculating Ratio A or B, consult table to determine number of parts of line.

Examples

- To find the number of parts of line needed when weight of load and single line pull are known, and using Bronze Bushed Sheaves.

$$\text{Ratio A} = \frac{72,180 \text{ lbs. (load to be lifted)}}{8,000 \text{ lbs. (single line pull)}} = 9.06 \text{ (Ratio A)}$$

Refer to ratio 9.06 in table or number nearest to it, then check column under heading "Number of Line Parts" = 12 parts of line to be used for this load.

- To find the single line pull needed when weight of load and number of parts of line are known, and using anti-friction bearing sheaves.

$$\text{Single Line Pull} = \frac{68,000 \text{ lbs. (load to be lifted)}}{7.32 \text{ (Ratio B of 8 part line)}} = 9290 \text{ lbs.}$$

9,290 lbs. single line pull required to lift this load on 8 parts of line.

- To find the lift capacity when the parts of line and single line pull are known, and using anti-friction bearing sheaves.

$$\begin{aligned} &10,000 \text{ lbs. (single line pull)} \\ &\times 4.71 \text{ (ratio B of 5 parts of line)} \\ &= 47,100 \text{ lbs. (Lift Capacity)} \end{aligned}$$

10,000 lbs. single line pull with 5 parts of line will accommodate 47,100 lbs. lift capacity.